



Model R-9777 Air Conditioner / Heater

INSTALLATION INSTRUCTIONS

NOTE

1. Please read instructions all the way through, making sure you have all the parts and tools.
2. While working on or around a vehicle, disconnect the battery to prevent accidental start-up or electrical shorts.
3. Use care so as not to release any R-134a refrigerant into the atmosphere.
4. A/C systems operate under high pressure. At 77°F the R-134a container will be pressurized to approximately 80 psi. Use caution when working with these materials. Goggles are recommended.
5. To function properly the A/C system must be clean and dry. Keep caps or protective covers on all refrigerant hoses and fittings until final assembly.

BEFORE STARTING

1. A compressor, compressor bracket, belts and refrigerant hoses are required to complete the installation. These items may be obtained from your RED DOT Distributor.
2. The compressor must have sufficient capacity to allow the unit to deliver the rated BTU output. An 8 cubic inch compressor turning faster than 1,750 rpm is required.
3. For pressurizing the cab and drawing fresh air, 78R 5110 remote mount filter is available with booster blower (73R 9202-12V or 73R 9204-24V).

MOUNTING THE UNIT ON CAB ROOF

1. Connect drain hose and 90° elbows as provided in the installation kit (RD-3-9146) to the unit. (See Figure 1)
2. Determine the location for mounting the heater-air Conditioner unit per Red Dot template.
 - a. Refer to figure 2.
 - b. Mark the front-to-rear centerline of the cab on the outside of the cab roof.
 - c. Place the mounting template on the roof using the centerline as a guide.
 - d. Ensure that air flow to the unit is not obstructed.
 - e. Do not mount the unit with the front lower than the rear, as this will prohibit water drainage.
 - f. Avoid cuffing roof stiffeners if possible. If stiffeners are cut or roof is weakened due to the cut-out, reinforcement may be required.
3. Tape the template to the roof at the desired location. Mark the roof cut-out area (scribe the roof).

NOTE: Before taping the template to the roof, decide what direction the unit is to be oriented. It is recommended that the "recirc inlet" be to the rear and the "discharge air" be positioned toward the front of the cab (This puts the condenser at the front and the plumbing to the rear).

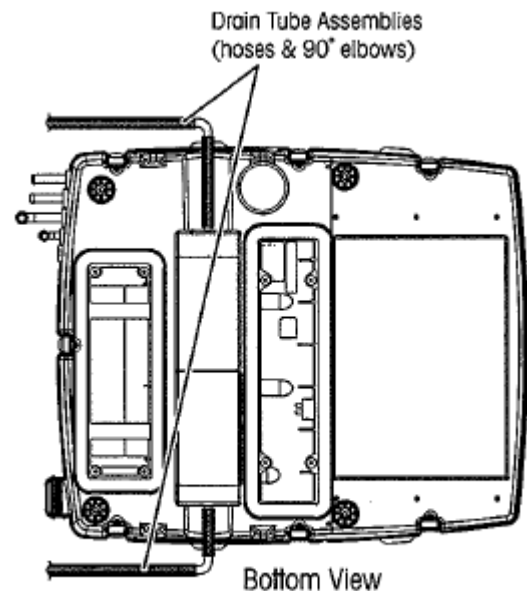
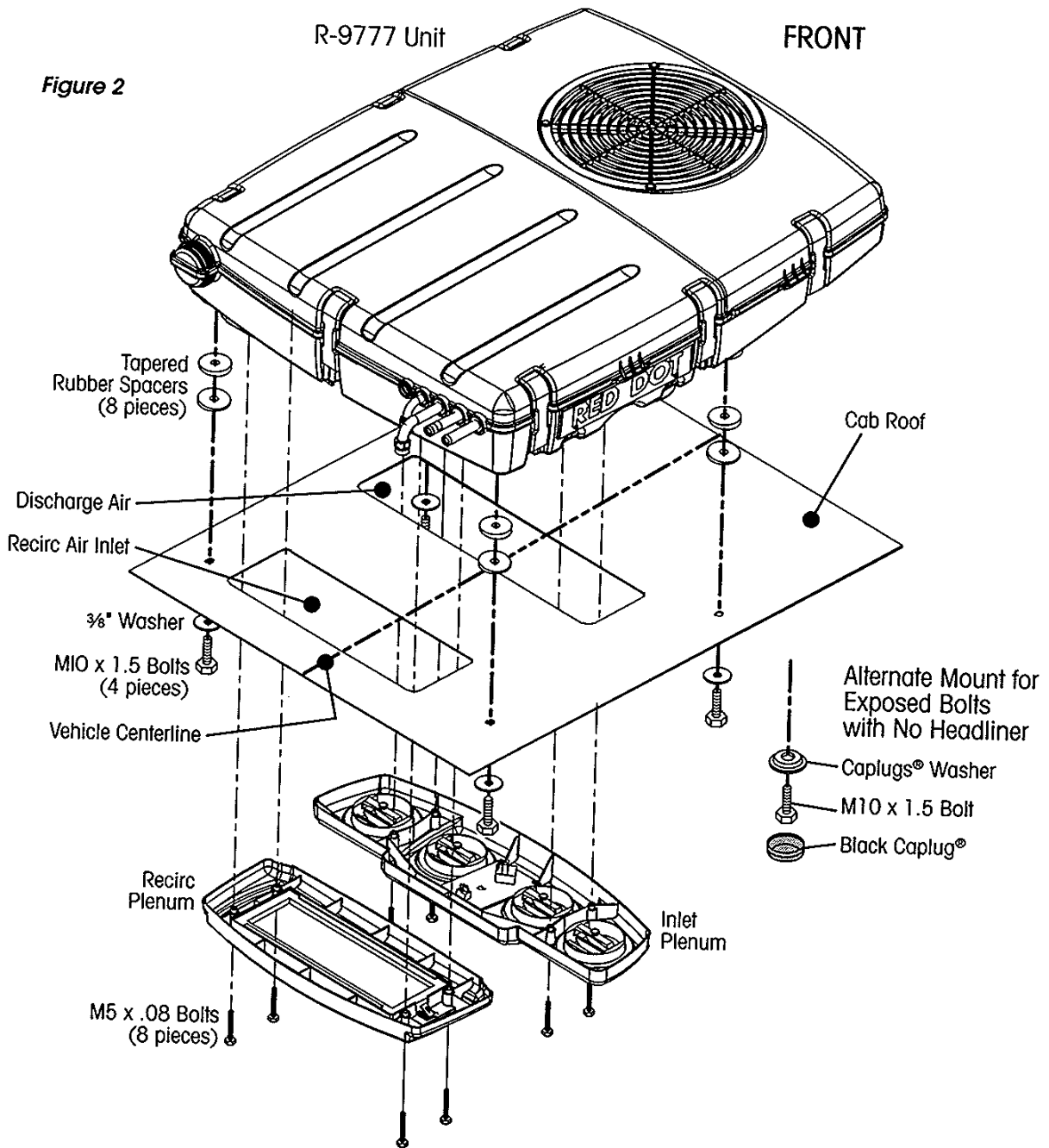

Figure 1



4. Cut the rectangular inlet and outlet holes into the roof where marked (stay inside the lines). Then remove the headliner and drill the 1/2" dia. mounting holes. Remove burrs and sharp edges. NOTE: The rectangular holes should go through the headliner, the mounting holes should not go through the headliner. If the headliner is difficult to remove (or if the cab has no headliner), drill the 1/2" dia. mounting holes through the headliner and use cap plug washers and cap plugs (supplied with kit) in conjunction with the M 10 mounting bolts as shown in figure 2.
5. Clean the outside roof area around the cut-out and mounting holes using a mild solvent.
6. Apply a bead of sealant around upper surface of roof cut-out and mounting holes. Completely fill bolt holes with silicone to ensure proper sealing. Also, place two rubber tapered spacers on each of the mounting holes and rotate the spacers relative to one another to level the unit on the roof (figure 2).

Red Dot Corporation P.O. Box 88790, Seattle, WA 98138 (425) 251-6897 Fax (425) 251-3934

7. Set unit on cab.
8. Apply sealant around bolts to prevent water leakage into cab.
9. Install four mounting bolts.

NOTE: Do not use an impact wrench to install the mount bolts. Do not exceed 25 lb.-ft torque on the mount bolts.

NOTE: Apply adhesive sealant to the mounting hole locations as needed.

REFRIGERANT HOSE INSTALLATION

1. Cut hose to proper length. Make cut at right angles to centerline of hose. Blow cut hose with clean dry air after cutting to insure no foreign particles are left in hose. Install the appropriate steel bead lock fitting on the end of the hose and crimp fitting using crimper No. 79R 1510. A #12 suction line is recommended in place of the #10 for increased cooling capacity. Use a step up fitting to accomplish this.
2. Route hoses over the top of cab and down the back wall to the compressor. On tilt cab vehicles, route hose to the cab pivot and then to compressor.
3. Use clamps to secure hoses and prevent hose movement. Hoses must not come in contact with hot vehicle components, exhaust manifolds, etc., and they should not be subjected to mechanical abrasions.

SECURE DRAIN HOSES

1. Secure drain tube with tie wraps. Attach to refrigerant hoses only if they run downhill properly.
NOTE: Be cautious not to over-tighten tie wraps. Otherwise the drainage may be restricted.
2. Inspect to make sure that drain tubes are not kinked, especially at back of cab.

AIR DIFFUSER AND RECIRC PLENUM

NOTE: Unit is wired for negative ground.

1. Disconnect battery.
2. **Orange and brown wires (condenser fan circuit):** Connect the orange wire to the ignition switch supplied power through a 30 amp circuit breaker (15 amp/24V) and the brown wire to ground.
3. **Red wire and black wire (motor blower circuit):** Connect the red wire to ignition switch supplied power through 30 amp circuit breaker (15 amp/24V) and the black wire to ground.
4. **Green Wire (compressor clutch circuit):** Connect to compressor clutch. Route the wire around the hinge point before connecting to compressor clutch on tilt-cab installations.
5. See Wiring Schematic (RD-3-9609) provided in installation kit.

SECURE DRAIN HOSES

1. Reinstall the headliner (if it was removed).
2. Place cable control converter through control panel ("D" hole from inside of plenum) then tighten the nut on the outside of the panel over the converter. Push the control knob provided in the kit over the shaft of the converter. (connect unit wiring to the rocker switch and the fan switch, refer to the Wiring Schematic for terminal information).
3. Place the control/distribution plenum assembly up to headliner so that it covers the large rectangular cutout (curved side of the plenum toward the condenser end of the unit) and start one of the mount bolts.
4. Start the remaining bolts and tighten plenum assembly bolts evenly until the plenum fits snugly against the headliner.

NOTE: Do not use an impact wrench to install these bolts. Do not exceed 8 lb.-ft torque for plenum bolts.

5. Remove the filter from the recirc/filter plenum by turning the quarter turn fastener counterclockwise and then removing the grill and filter.
6. Place the recirc/filter plenum up to the headliner so that it covers the small rectangular cutout (curved side either away from or toward the condenser) and start one of the bolts.

Red Dot Corporation P.O. Box 88790, Seattle, WA 98138 (425) 251-6897 Fax (425) 251-3934

7. Start the remaining bolts and tighten the plenum assembly bolts evenly until the plenum fits snugly against the headliner.

NOTE: Do not use an impact wrench to install these bolts. Do not exceed 8 lb.-ft torque for plenum bolts.

8. Replace the recirc filter and grill into the recirc/filter plenum.

FINAL ASSEMBLY AND CHECK

1. Evacuate the system, test for leaks and charge with R-134a. The unit requires 3.2 to 3.4 pounds depending on hose lengths.
2. Connect the battery.
3. Turn the ignition switch to the "on" position, turn the blower switch to the high speed position, flip the a/c rocker switch to the "on" position:
 - a. The a/c clutch should click on and be engaged.
 - b. The evaporator blower should be turning at high speed.
 - c. The condenser blower should be turning.
4. Turn the fan switch to medium and low positions and check that the evaporator blower slows down.
5. Turn the fan switch to the "off" position and compressor clutch should disengage.
6. Start engine and run at 1500-2000 rpm. Turn unit on "full cold", "high fan". Check gauges for normal pressures for R-134a.